



PACKAGING WITH PASSION

JEWELRY PACKAGING

PACKAGING WITH PASSION

Packaging with Passion

We design and manufacture packaging that makes an impression. Your product must have the optimal packaging and we make sure the imprint on your customers' experience only leaves a small imprint on the surroundings.

At Concept International we offer following:

- Innovative and creative design
- Sustainable materials and constructions
- Flexible packaging solutions
- 3D design and 3D printed models
- Partnership and guidance on your next packaging project

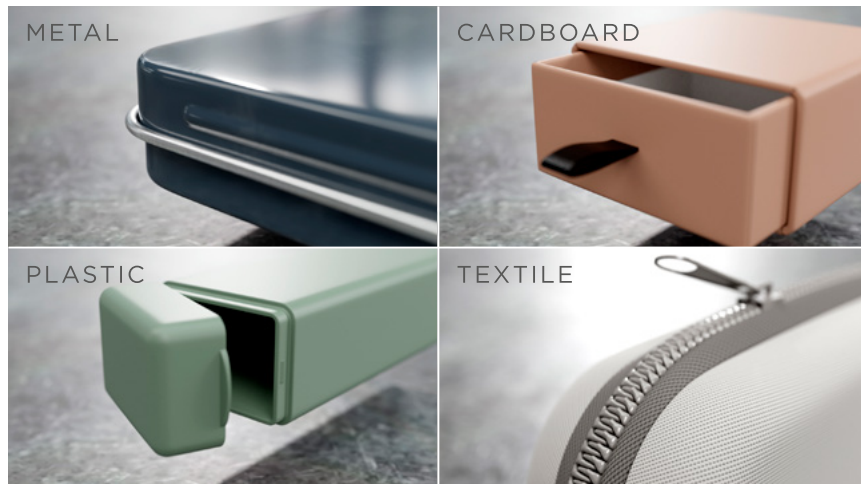

This is how we work

Packaging is not just packaging and Concept International is far from just a supplier. With your product in focus, we develop a packaging, that stands out on the shelves and at the same time fulfill the needs you may have to visibility, sustainability, functional properties, and co-packaging.

The process is as follows:

- Brief and guidance
- 3D visualization - we can even place the packaging in a defined environment/display
- Dummy sample or 3D printed sample for checking of construction and size
- Approval sample with final printing before mass production
- Production at factories with **ISO 9001, ISO14001** and **SA8000**
- Production and Quality control
- Shipment and delivery
- Debrief and evaluation of packaging performance

With us as partner, the packaging increases the value of your product.



*Ask our sales department
for our other free presentations
or find out more about us at:
www.conzept-int.com*

Content

LUXURY JEWELRY PACKAGING | **05**

CONSTRUCTION AND DESIGN | **06**

CHOICE OF MATERIALS | **08**

INLAY SOLUTIONS | **09**

SUSTAINABLE JEWELRY PACKAGING | **11**

THIS IS HOW WE WORK | **12**

PACKAGING WITH SECOND LIFE | **14**

COMMUNICATE ON YOUR PACKAGING | **15**

STORAGE AND TRAVELLING | **17**

BIG JEWELRY BOX | **18**

TRAVEL JEWELRY BOX | **19**

JEWELRY BAGS AND POUCHES | **20**

WALK YOUR BRAND | **21**





Luxury Jewelry Packaging

High quality and a touch of luxury is our focus when we develop customized jewellery packaging. We have the expertise to design packaging that fits exactly your jewellery.

With special selected paper materials and beautiful fabrics, we can create unique luxury packaging that will suit your needs and also look good on Instagram.

↶ Image A

Boxes wrapped in exclusive fabrics to present and showcase your jewellery.

↗ Image B

Small bags in silk and velvet to wrap and protect your jewellery.



Construction and design

Design Process

Our jewellery boxes are designed with quality and aesthetics in mind. We construct the boxes and inlays specifically for your needs. The boxes can be wrapped in special paper or selected fabric and ribbons can be attached. We can customize them only for you.



Image A

Shapes, materials and finish are many, you just have to let us know what you want.

A

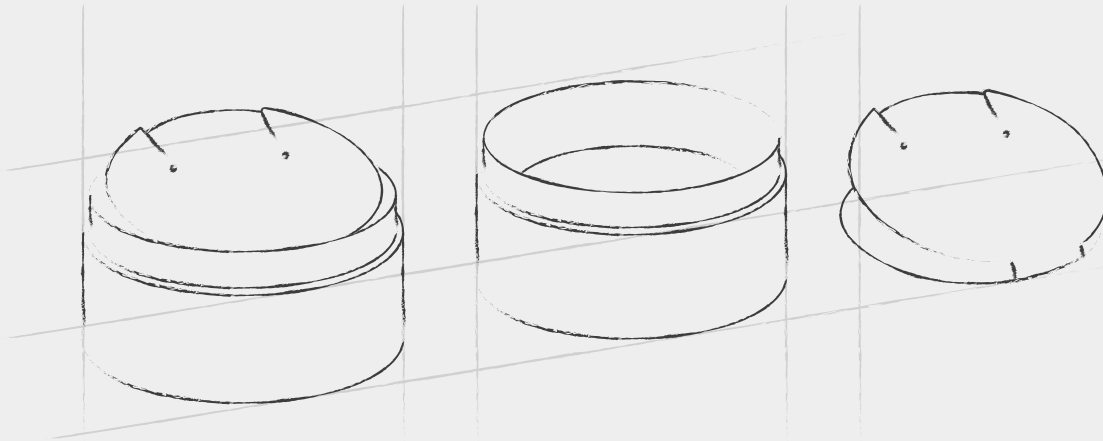

← **Image A**

Drawings to show the idea.

↓ **Image B**

3D drawings to show the final effect with colors and materials.

B



Construction and design

Construction

To develop the boxes we start with the jewellery, what needs to go inside. How do you want them to be presented. When shape and construction is in place we look at the wrapping material.

Choice of materials

The choice of materials are many. We help to present materials that are workable for wrapping and for protecting your jewellery.

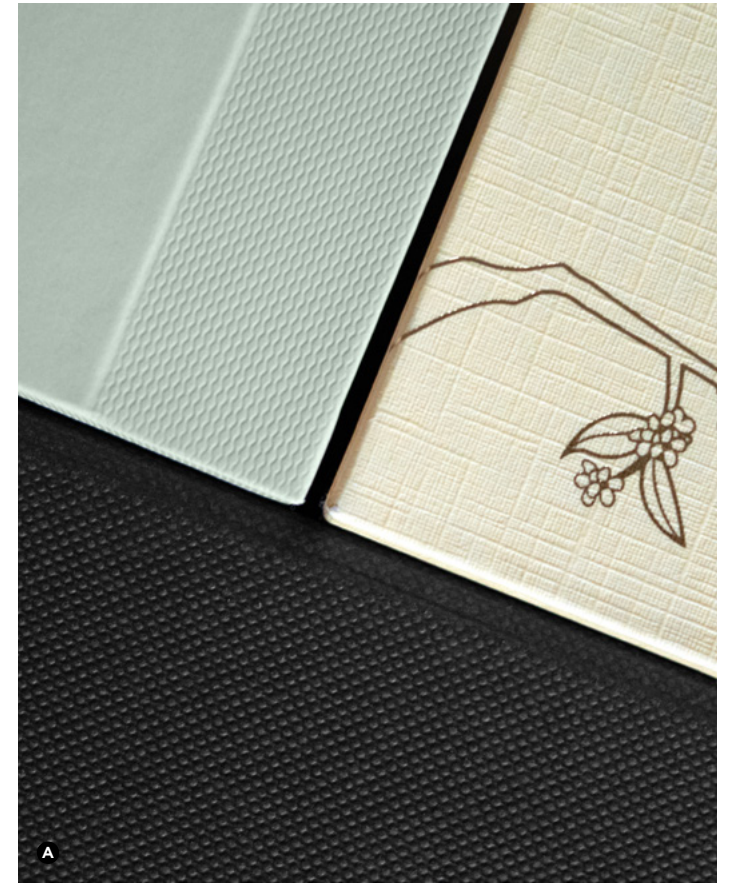

← ↑

Image A+B

Soft, shiny, matt, more environmental friendly, it is all available. It only depends on what you want.

Inlay solutions

Inlays customized for the specific jewelry and with different purposes. In this way our clients can obtain more flexibility and limit the amount of sizes of boxes.

We are always on the search for new materials, more sustainable materials, but at the same time materials that are anti oxidative and does not fade easily.





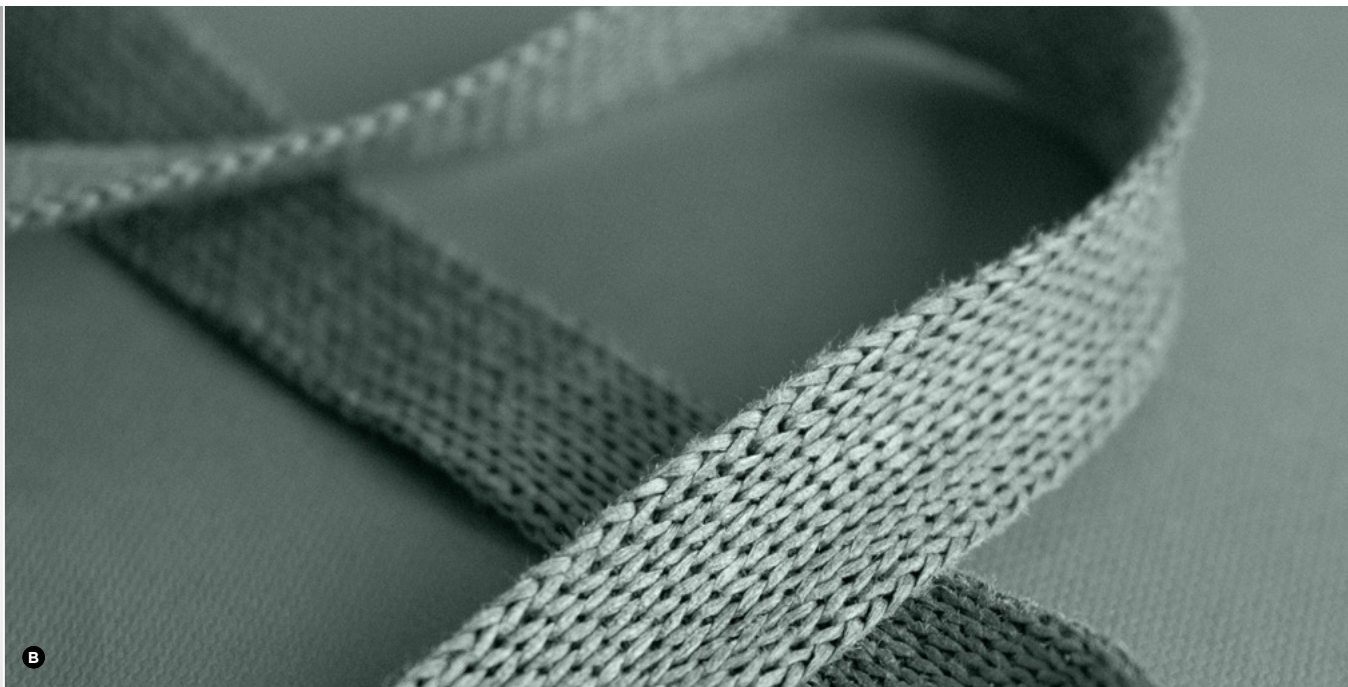

Sustainable Jewelry Packaging

Sustainability. Environmental impact. Whatever you choose to call it, the focus on the future of the planet has shifted from 'important' to 'non-negotiable' for businesses and consumers alike.

Conzept International has many years of experience in producing more environmental friendly packaging, and we are happy to help you make the right choices in relation to construction and materials.

▮ Image A

We try to avoid the traditional plastic boxes and make our boxes plastic free.

▴ Image B

Materials from more responsible resources are available, like ribbons in paper instead of polyester.



This is how we work

Design process and sustainability

At Conzept International, accountability is key to how we produce our packaging, how it is used and finally how it is waste sorted. We develop innovative solutions and are ambitious about how we can re-think the way we produce and how the packaging is being used with a less imprint on the surroundings.

When we design the packaging we take following into consideration:

- Reduce the amount of packaging material by making the boxes more generic with multi purposed inlays.
- Make sure the material comes from certified responsibly sourced or recycled resources
- All paper materials to be FSC®
- All materials to be REACH compliant
- Minimize or avoid to use plastic
- Use quality materials, so the packaging will be kept and re-used for storage/2nd life.





A



B

← ↑

Image A+B

More environmental friendly packaging can still have a touch of luxury. Working with uncoated surfaces, organic and recycled materials, sustainable foils, ribbons, deep embossments and spot UV - all nice effects that makes the packaging look beautiful.

A

← **Image A**

Make the packaging so beautiful that it will be kept for storage and thereby have a 2nd life.

↓ **Image B**

Construct the packaging so ribbon and cardboard can easily be separated for correct waste sorting.

Packaging with second life

Beautiful boxes

Jewelry often carries a story. You want to protect that and keep it in a beautiful box for life. We create the jewelry boxes, so it is kept and used for a long time.

**B**

Communicate on your packaging

Clearly communication for easy waste sorting

Make sure you communicate on your packaging if you are using materials from responsible sources and how to recycle the packaging after use.



Image A+B

Inform your consumers the resource used for the packaging and how to recycle correctly after use.







Storage And Travelling

When storing jewellery, whether for protection or travel, the key is to prevent damage, tangling and loss. Conzept International develops various storage and travel solutions for your jewellery.

▮ Image A

Compact cases with built-in compartments are great for keeping the jewellery secured.

▴ Image B

Store delicate pieces in soft pouches or small cloth bags.



Big jewelry box

For storage and protection

Jewelry boxes for storing or travelling is a must. When you have had one, you will never let it go. We create jewelry boxes with storage options in different constructions and fabrics. All customized for our clients.



Image A

Construct the box with different trays and compartments to protect your jewelry from scratches and tangling. In this way you allways have your jewelry safe and organized.



A



← ↓

Image A+B

Dividers, padded slots and hooks for necklaces, rings, earrings and bracelets to prevent tangling or damage.

Travel jewelry box

Keep your jewelry safe

A travel jewelry box is a compact and secure solution for protecting your valuables while on the go. Small enough to fit in your handbag and to be kept in the safe on your end destination.



B

Jewelry bags and pouches

Storage and gifting

Using bags and pouches for storing and gifting is a practical and versatile solution. Use soft materials to prevent scratches. Use the bags for odd sizes, selected items and small items.



Image A

Organic fabrics with a touch of luxury.



Image B

Develop your packaging, so there is a corporate identity in your product line. Use sustainable materials like FSC®.



Image C

Small drawstring bags for more odd size jewelry, pearls or pendants.



A



B



C

Walk your brand

Shopping bags

Shopping bags are a good way to “Walk Your Brand”. It is a practical product that can be used again and again. We can print them with nice statements and the fabric can be made from recycled materials (Global Recycle Standard) or from organic or GOTS certified material.



Image A+B

Shoppers in GOTS, organic or recycled materials.



B



NICOLAI DELEURAN
CEO
nd@conzept-int.dk
Tel: +45 40 23 54 53



KARINA S. BERNTSEN
Head of sales
kb@conzept-int.dk
Tel: +45 31 39 77 06

Concept International // Vølundsvej 6D, 3400 Hillerød, Denmark
Tel (0045) 70 25 21 70 **Mail** info@conzept-int.dk **Web** www.conzept-int.com